

ARMADO FÁCIL

MODELO AF3-02

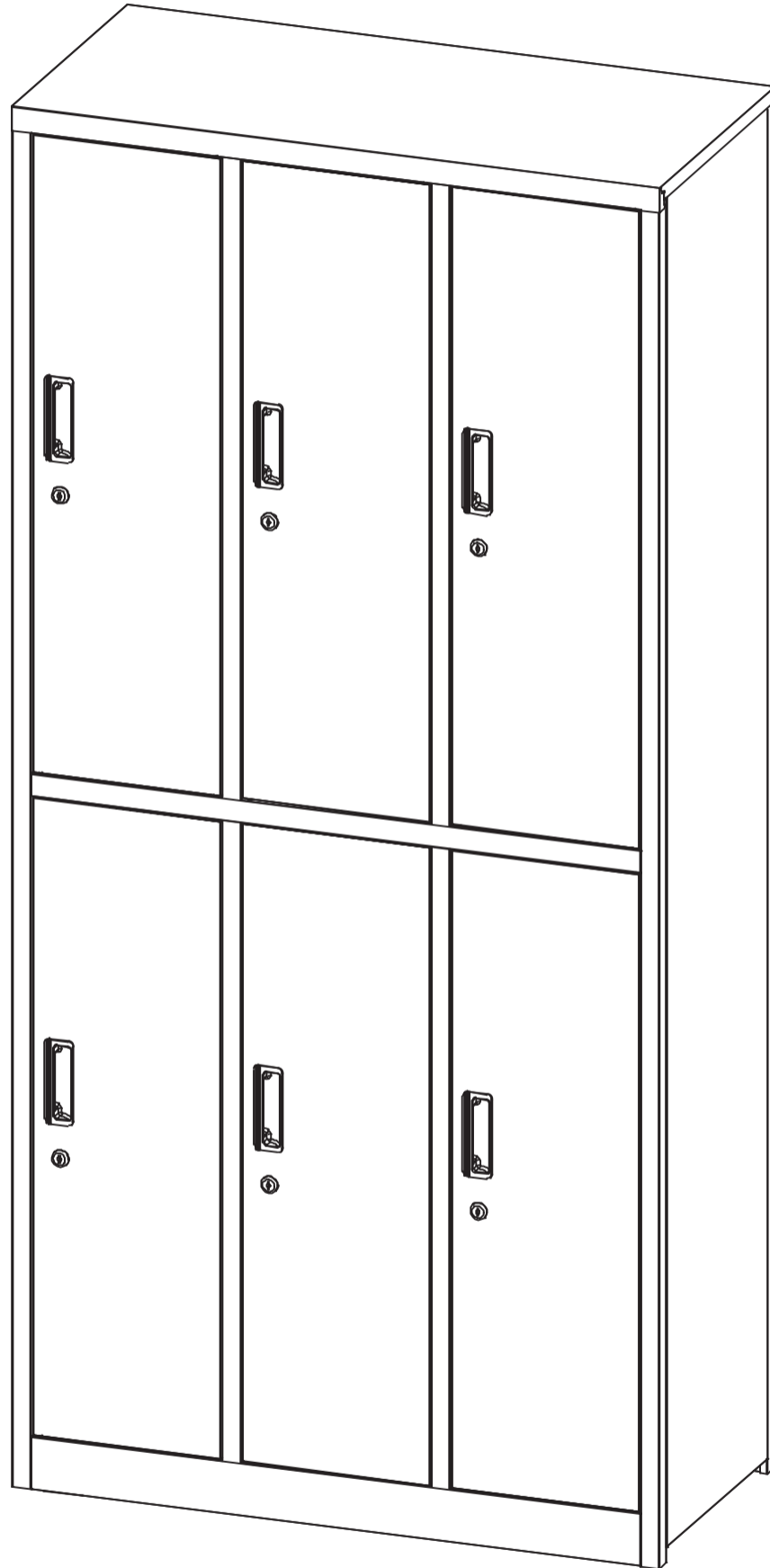

Herramientas necesarias:

**Atornillador de Cruz
(no incluido)**

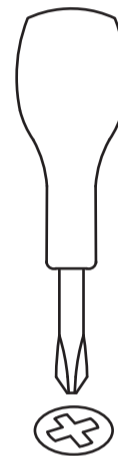

¡Precaución!

Para evitar volcamiento del mueble no debe sobrecargarse en bandejas/compartimentos superiores.

Para evitar volcamiento puede fijarse a la pared (no se incluyen herramientas ni tornillos de fijación).

Este mueble debe ser armado por un adulto. En caso de duda, busca asesoramiento profesional. Lee y sigue cada paso de las instrucciones cuidadosamente.

ARMADO FÁCIL LISTA DE COMPONENTES

Tapa Superior (x1)



Tapa Central (x1)

Con ranuras en bandeja

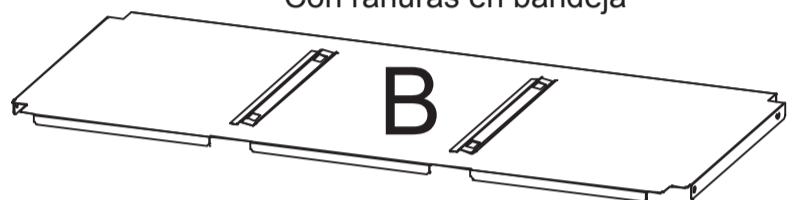

Tapa Inferior (x1)

Con ranuras en bandeja



Bandejas



Izquierda
(Grande)

x2

Central

x2

Derecha

x2

Barras

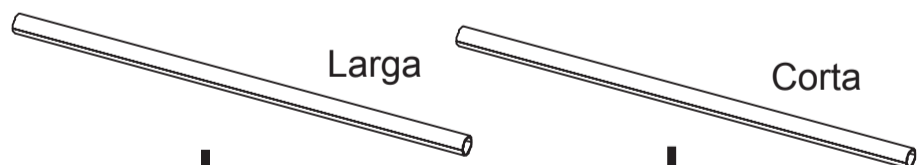

I x2

J x4

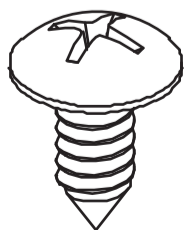

x16
Tornillo "A"

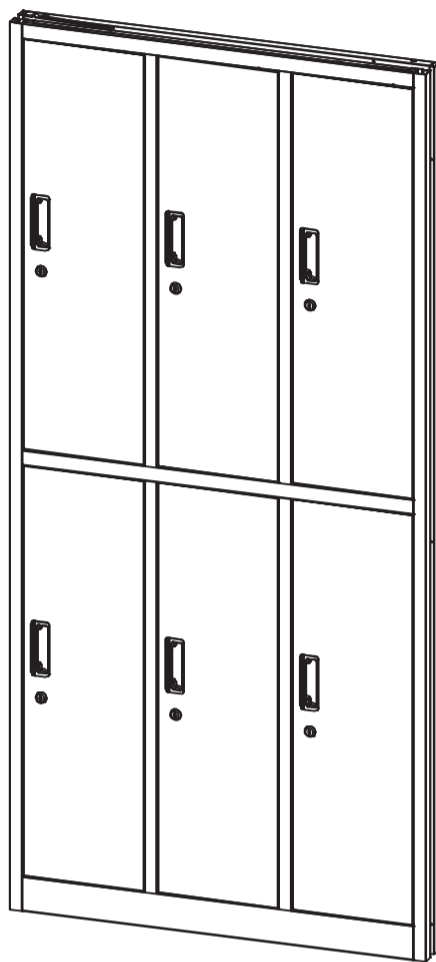

x1

Soporte
pie de altura

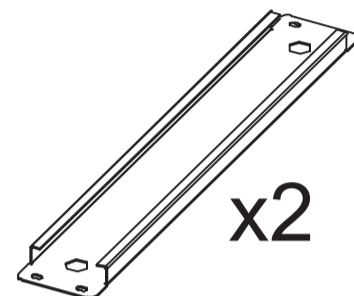

x2



x8
Tornillo "B"

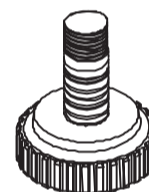

x4

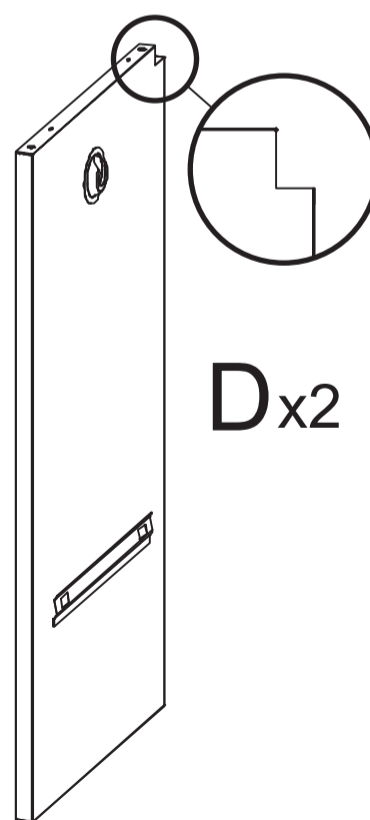

D x2

Placa vertical
superior (corta)

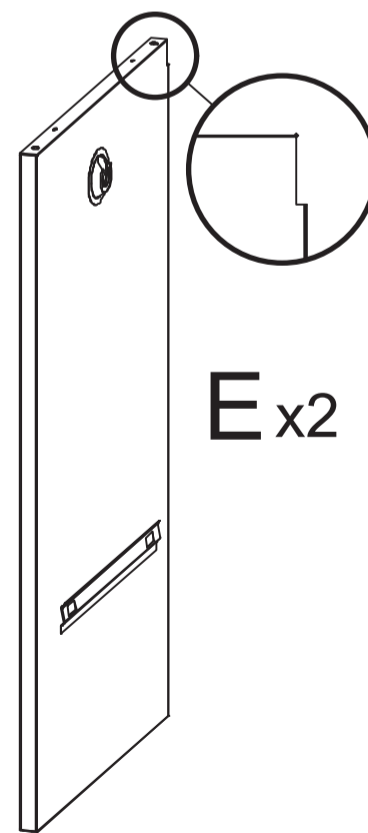

E x2

Placa vertical
inferior (larga)

ARMADO FÁCIL PASO 1 · APERTURA

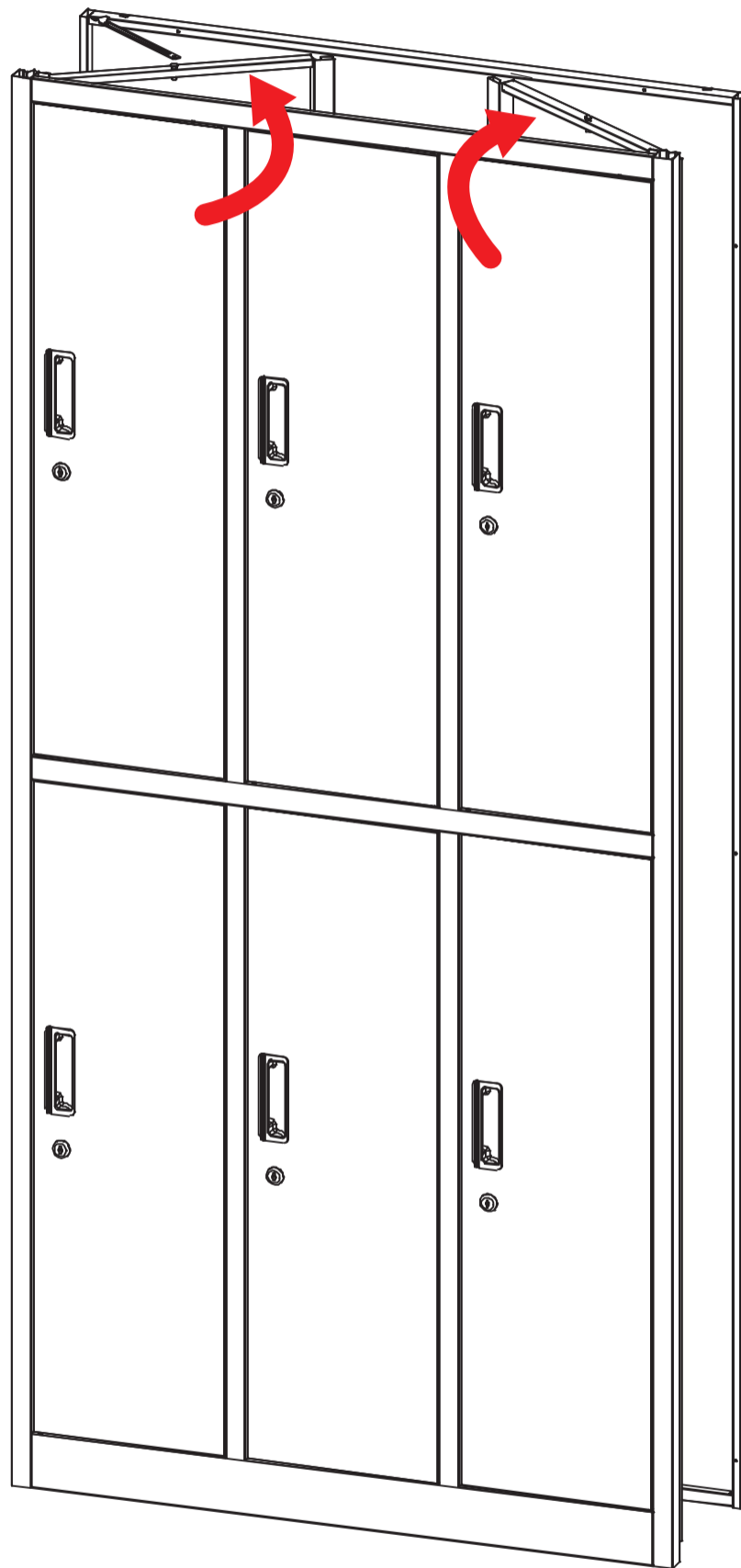

ARMADO FÁCIL PASO 2 · FIJACIÓN BASE

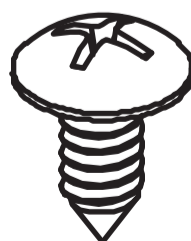
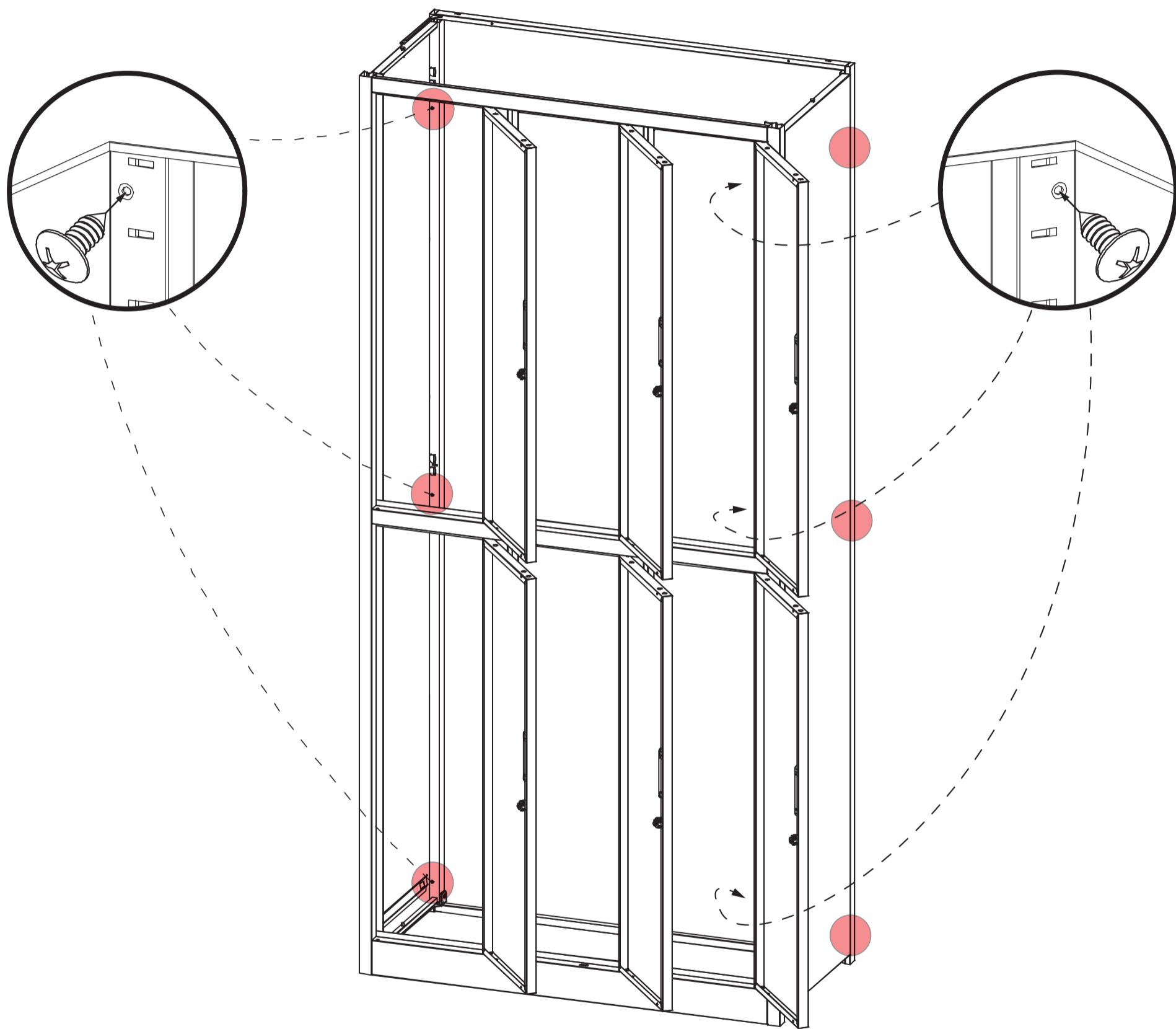

x6
Tornillo "A"

ARMADO FÁCIL PASO 3 · TAPAS CENTRAL E INFERIOR

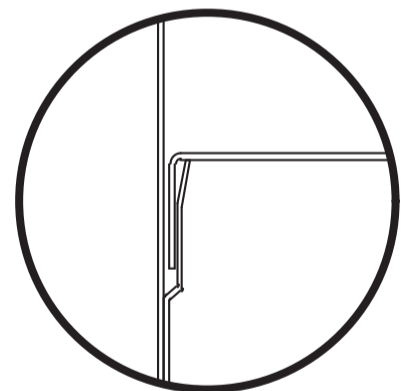
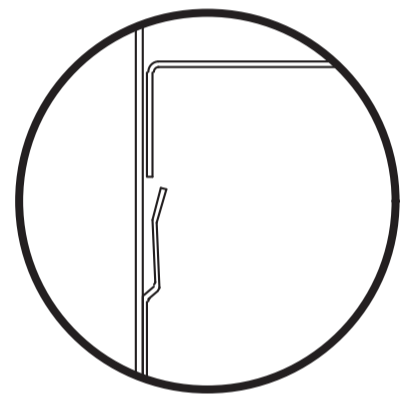
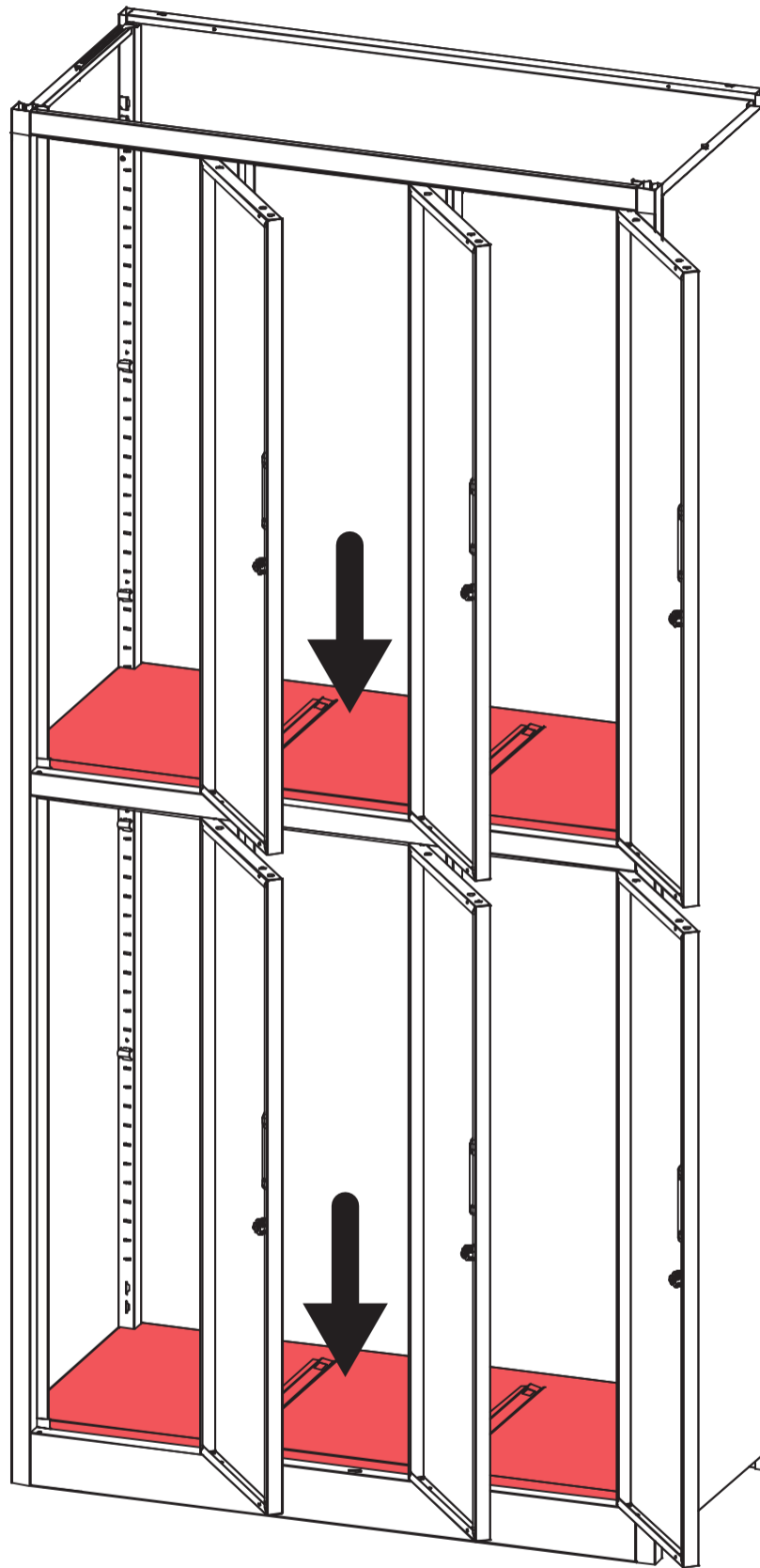
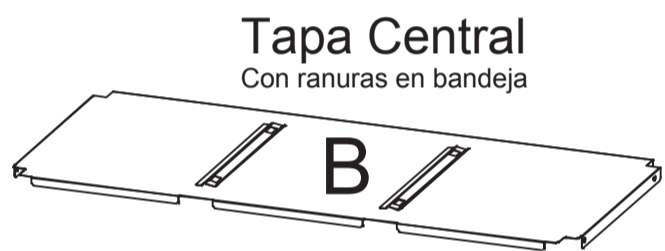

Enganche
atrás y costados

ARMADO FÁCIL PASO 4 · TAPA SUPERIOR

Tapa Superior A

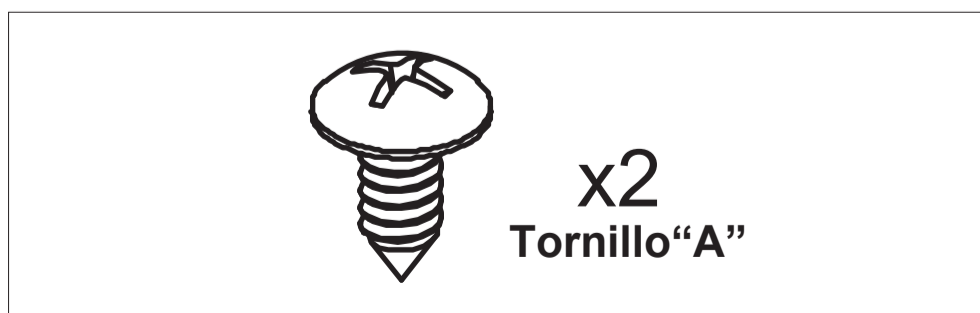
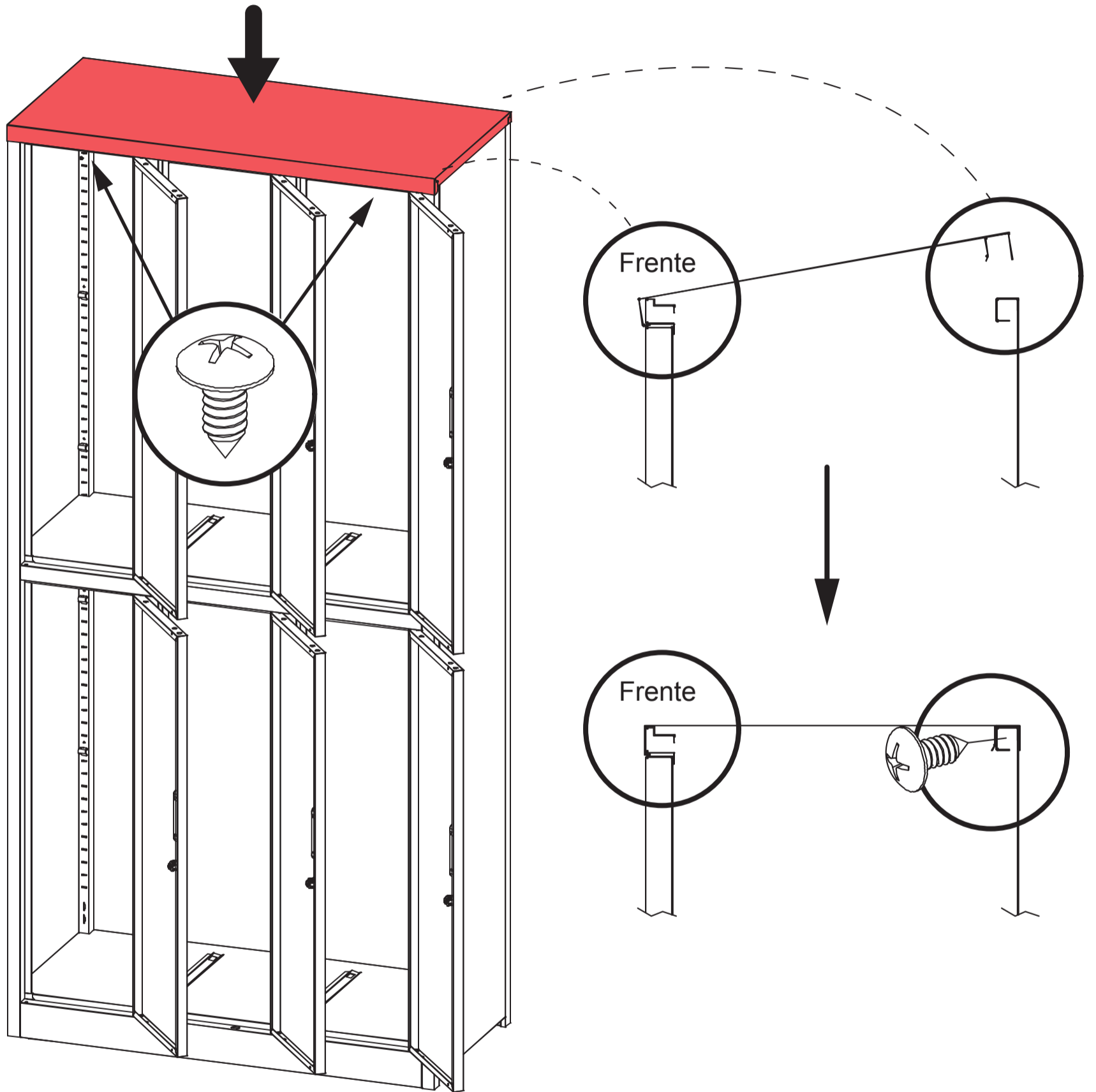

ARMADO FÁCIL PASO 5 · SEPARACIÓN VERTICAL

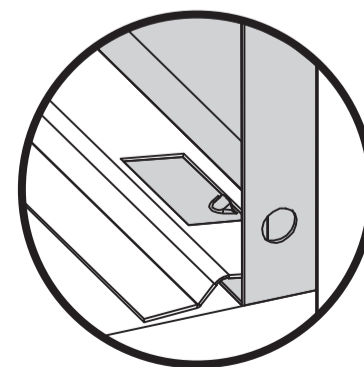
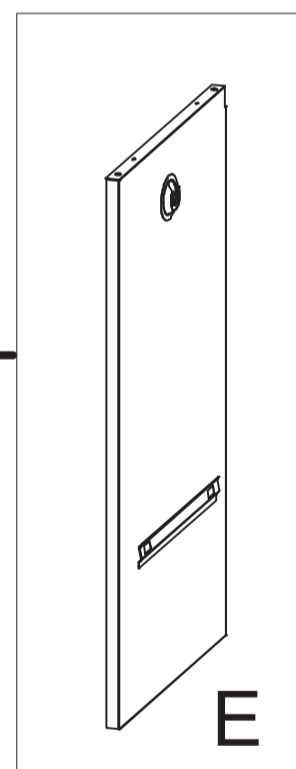
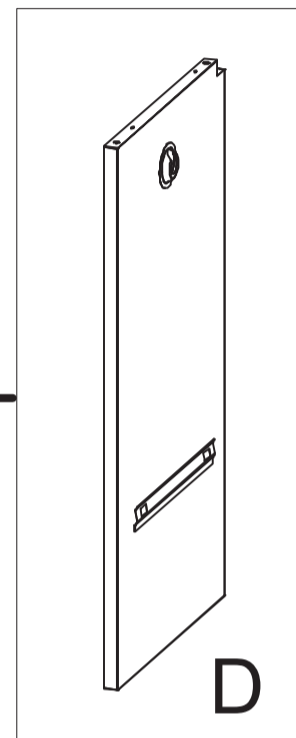
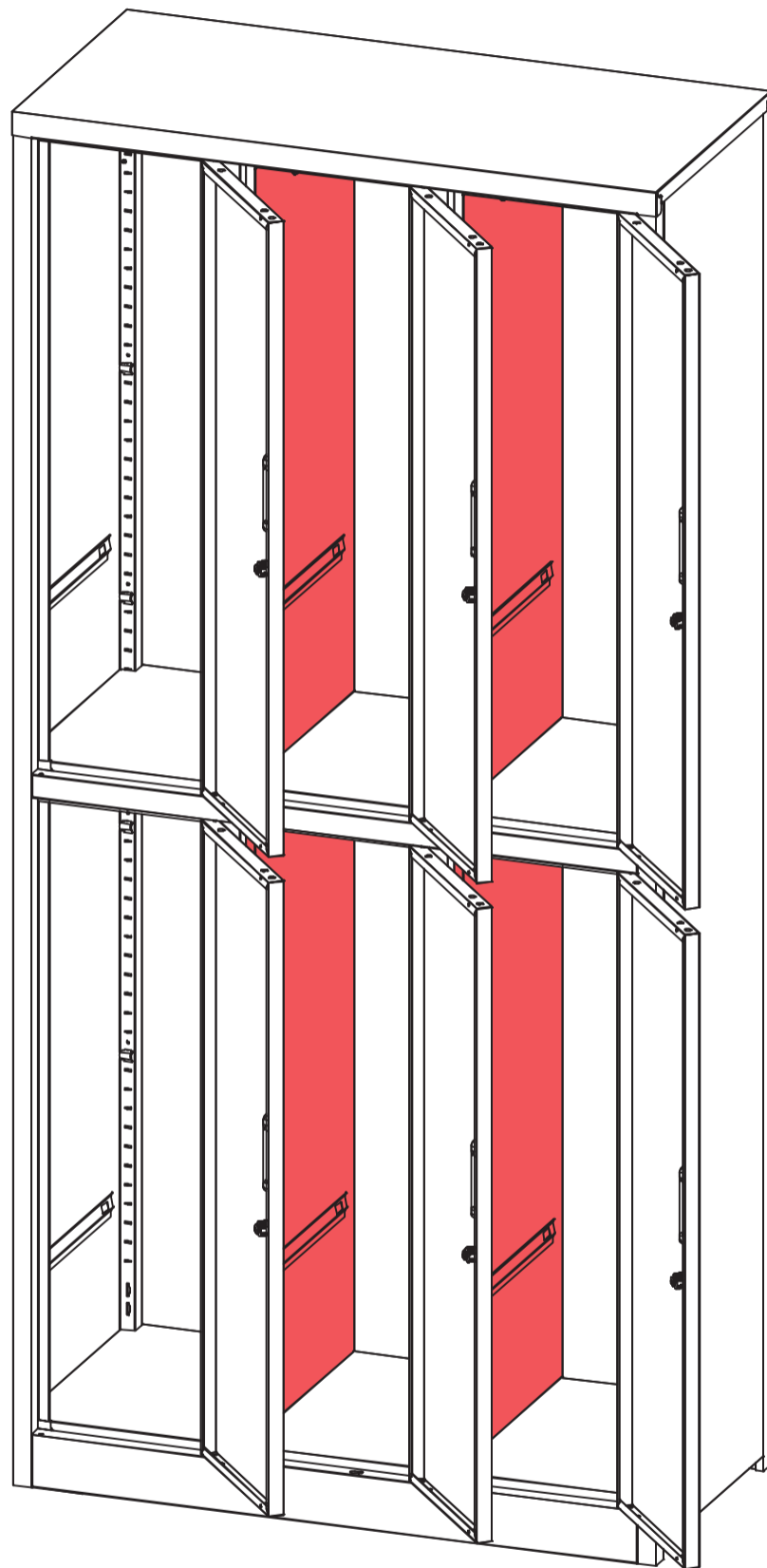
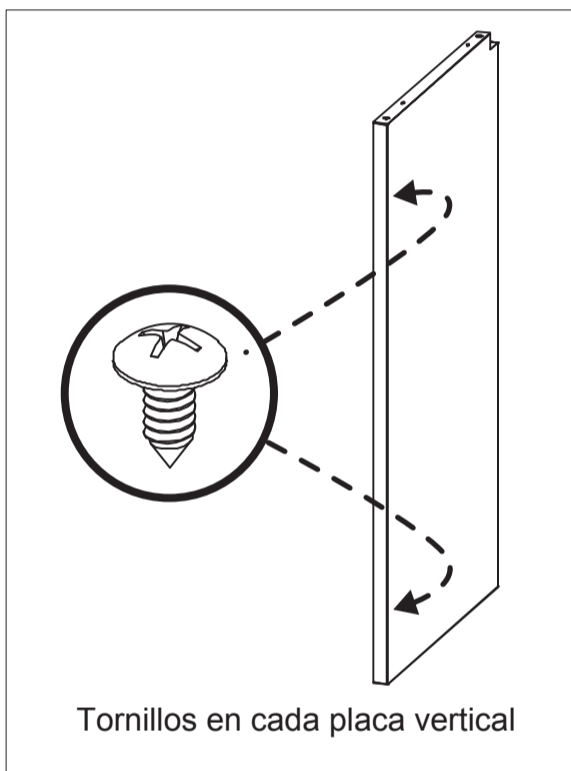

Enganche superior e inferior de cada placa vertical

ARMADO FÁCIL PASO 6 · BARRAS Y BANDEJAS

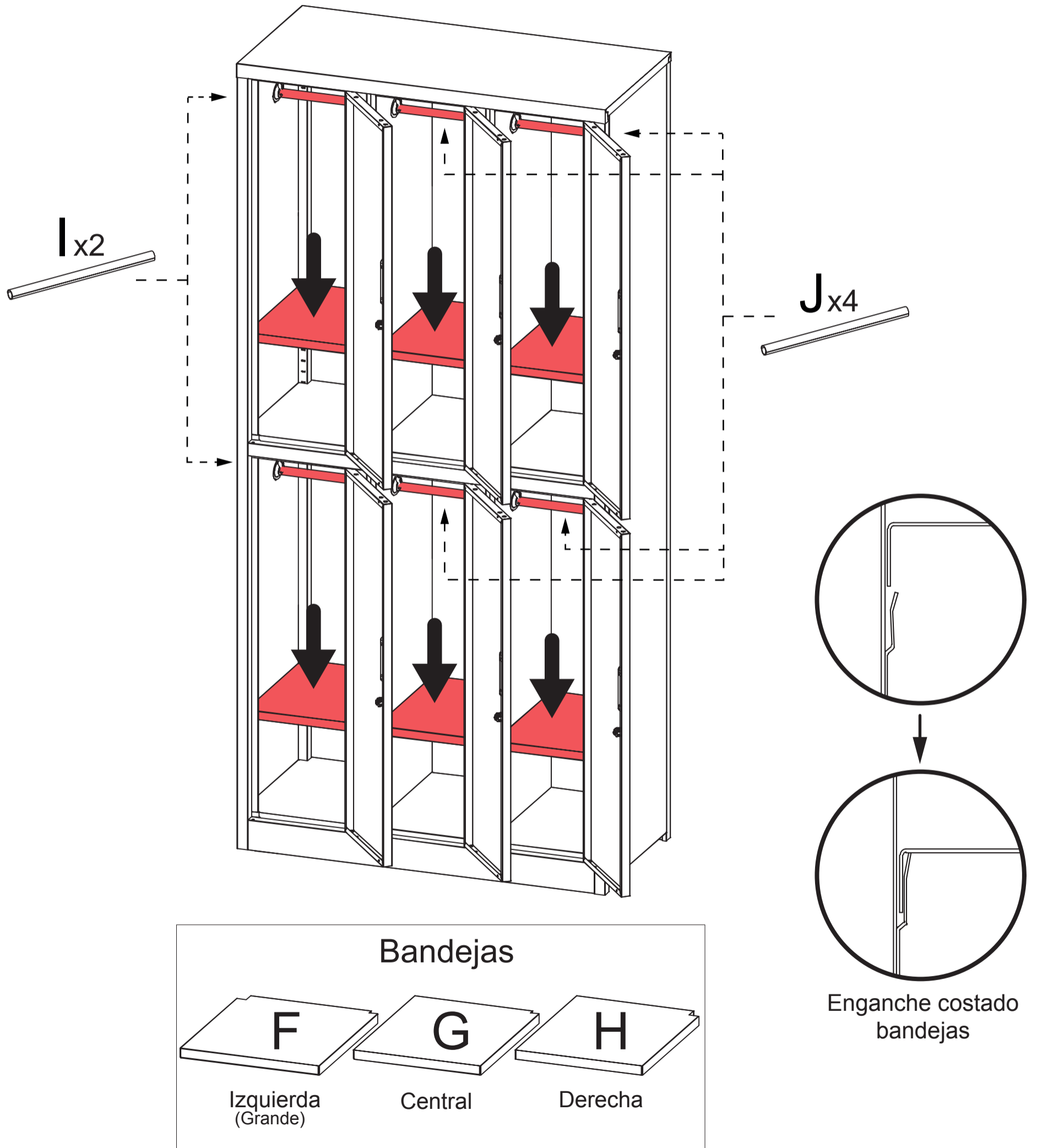

ARMADO FÁCIL PASO 7 · SOPORTE PIE DE ALTURA

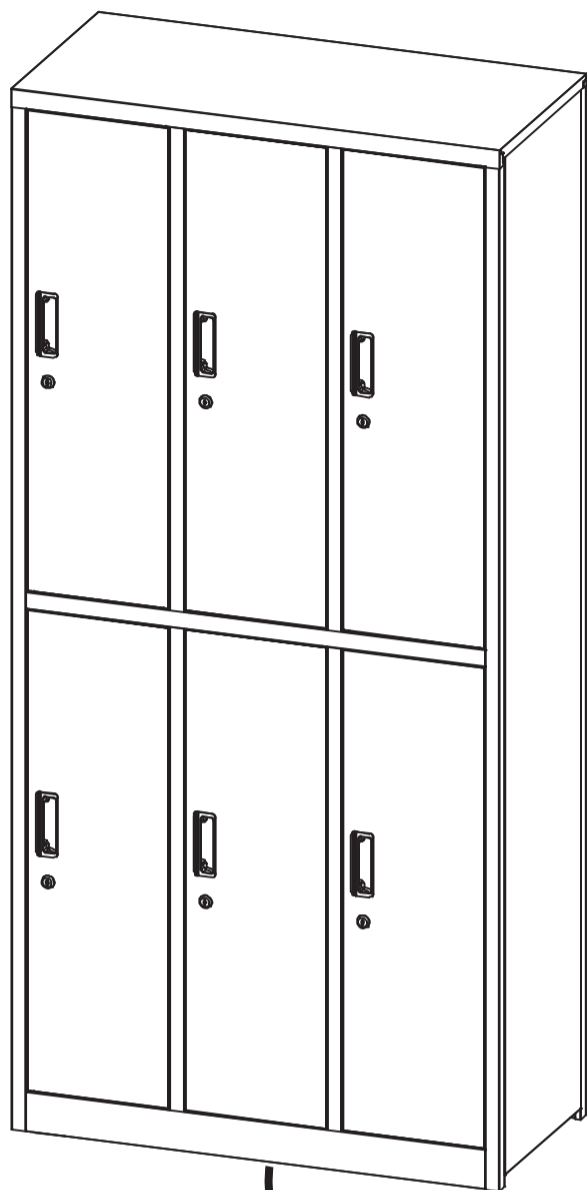

Zona Inferior

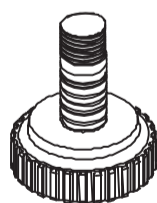
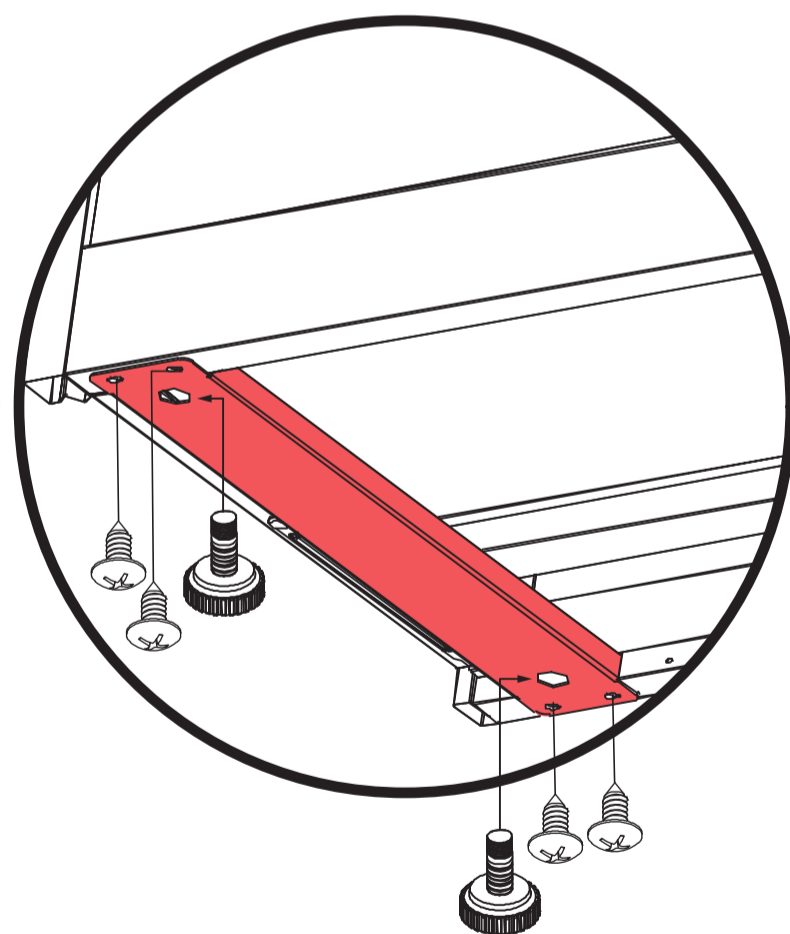

x4

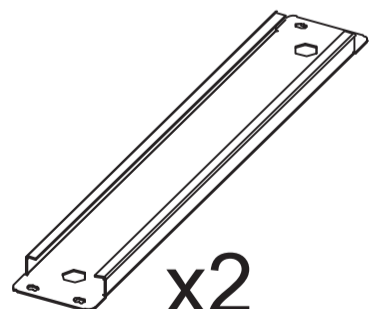

x2

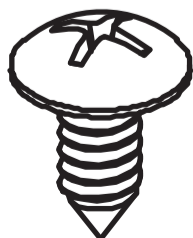

x8
Tornillo "B"

ARMADO FÁCIL

